

JVC

SERVICE MANUAL

COLOUR TELEVISION

AV-20F702

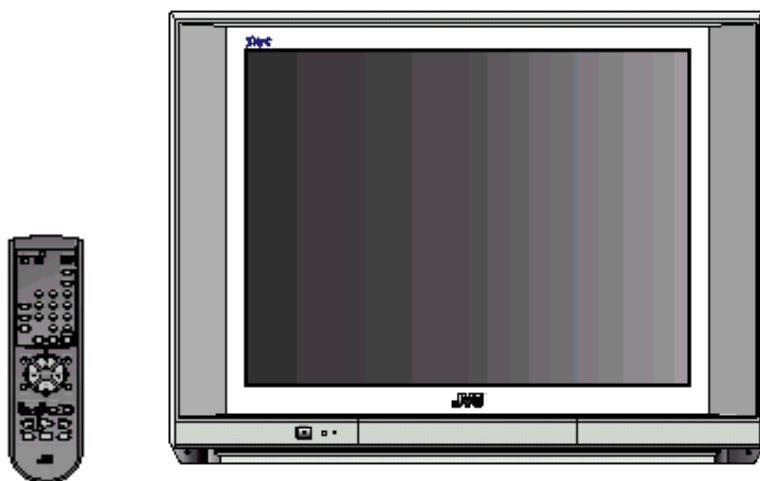

CONTENTS

■ SPECIFICATIONS	2
★ OPERATING INSTRUCTIONS (APPENDED)	
■ SAFETY PRECAUTIONS	3
■ SPECIFIC SERVICE INSTRUCTIONS	4
■ SERVICE ADJUSTMENTS	8
■ GUIDE FOR REPAIRING	13
★ STANDARD CIRCUIT DIAGRAM (APPENDED)	
■ PARTS LIST	20

SPECIFICATIONS

Items	Contents
Dimensions (W × H × D)	59.0cm × 44.4cm × 49.85cm
Mass	50.6lbs
TV System and Color system TV RF System Color System	CCIR(M) NTSC
TV Receiving Channels and Frequency VHF UHF CATV	2-13 14-69 01-97 (5A)-(A-3) 98-99 (A-2)-(A-1) 14-22 (A)-(I) 23-36 (J)-(W) 37-65 (AA)-(FFF) 66-125 (GGG)-(125)
TV/CATV Total Channel	180 Channels
Intermediate Frequency Video IF Carrier Sound IF Carrier Color Sub Carrier	45.75 MHz 41.25 MHz (4.5MHz) 3.58 MHz
Power Input	120V AC, 60Hz
Power Consumption	105W
Picture Tube	20"
Speaker	2" x 4-3/4", 8 ohm x 2
Audio Power Output	2.5 W + 2.5 W
Input (1 / 2 / 3)	Video : 1Vp-p 75ohm (RCA pin jack) Audio : -8dB, 47kohm (RCA pin jack) S-Video Y : 1.0Vp-p, 75 ohm C : 0.3Vp-p, 75 ohm
Component Input	Y: 1.0Vp-p, 75 ohm PB: 0.7Vp-p, 75 ohm PR: 0.7Vp-p, 75 ohm
Antenna terminal	75 Ω (VHF/UHF) Terminal, F-Type Connector
Remote Control Unit	RM-C309G

Design & specification are subject to change without notice.

SAFETY PRECAUTIONS

SERVICING NOTICES ON CHECKING

1. KEEP THE NOTICES

As for the places which need special attentions, they are indicated with the labels or seals on the cabinet, chassis and parts. Make sure to keep the indications and notices in the operation manual.

2. AVOID AN ELECTRIC SHOCK

There is a high voltage part inside. Avoid an electric shock while the electric current is flowing.

3. USE THE DESIGNATED PARTS

The parts in this equipment have the specific characters of incombustibility and withstand voltage for safety. Therefore, the part which is replaced should be used the part which has the same character.

Especially as to the important parts for safety which is indicated in the circuit diagram or the table of parts as a \triangle mark, the designated parts must be used.

4. PUT PARTS AND WIRES IN THE ORIGINAL POSITION AFTER ASSEMBLING OR WIRING

There are parts which use the insulation material such as a tube or tape for safety, or which are assembled in the condition that these do not contact with the printed board. The inside wiring is designed not to get closer to the pyrogenic parts and high voltage parts. Therefore, put these parts in the original positions.

5. TAKE CARE TO DEAL WITH THE CATHODE-RAY TUBE

In the condition that an explosion-proof cathode-ray tube is set in this equipment, safety is secured against implosion. However, when removing it or serving from backward, it is dangerous to give a shock. Take enough care to deal with it.

6. AVOID AN X-RAY

Safety is secured against an X-ray by considering about the cathode-ray tube and the high voltage peripheral circuit, etc.

Therefore, when repairing the high voltage peripheral circuit, use the designated parts and make sure not modify the circuit.

Repairing except indicates causes rising of high voltage, and it emits an X-ray from the cathode-ray tube.

7. PERFORM A SAFETY CHECK AFTER SERVICING

Confirm that the screws, parts and wiring which were removed in order to service are put in the original positions, or whether there are the portions which are deteriorated around the serviced places serviced or not. Check the insulation between the antenna terminal or external metal and the AC cord plug blades. And be sure the safety of that.

(INSULATION CHECK PROCEDURE)

1. Unplug the plug from the AC outlet.
2. Remove the antenna terminal on TV and turn on the TV.
3. Insulation resistance between the cord plug terminals and the external exposure metal **[Note 2]** should be more than 1M ohm by using the 500V insulation resistance meter **[Note 1]**.
4. If the insulation resistance is less than 1M ohm, the inspection repair should be required.

[Note 1]

If you have not the 500V insulation resistance meter, use a Tester.

[Note 2]

External exposure metal: Antenna terminal
Earphone jack

HOW TO ORDER PARTS

Please include the following informations when you order parts. (Particularly the VERSION LETTER.)

1. MODEL NUMBER and VERSION LETTER

The MODEL NUMBER can be found on the back of each product and the VERSION LETTER can be found at the end of the SERIAL NUMBER.

2. PART NO. and DESCRIPTION

You can find it in your SERVICE MANUAL.

IMPORTANT

Inferior silicon grease can damage IC's and transistors.

When replacing an IC's or transistors, use only specified silicon grease (YG6260M).

Remove all old silicon before applying new silicon.



Licensed by BBE Sound, Inc. under USP4638258 and 4482866.
BBE and BBE symbol are registered trademarks of BBE Sound, Inc.

SPECIFIC SERVICE INSTRUCTIONS

DISASSEMBLY INSTRUCTIONS

1. REMOVAL OF ANODE CAP

Read the following **NOTED** items before starting work.

- * After turning the power off there might still be a potential voltage that is very dangerous. When removing the Anode Cap, make sure to discharge the Anode Cap's potential voltage.
- * Do not use pliers to loosen or tighten the Anode Cap terminal, this may cause the spring to be damaged.

REMOVAL

1. Follow the steps as follows to discharge the Anode Cap. **(Refer to Fig. 1-1.)**
 Connect one end of an Alligator Clip to the metal part of a flat-blade screwdriver and the other end to ground. While holding the plastic part of the insulated Screwdriver, touch the support of the Anode with the tip of the Screwdriver. A cracking noise will be heard as the voltage is discharged.

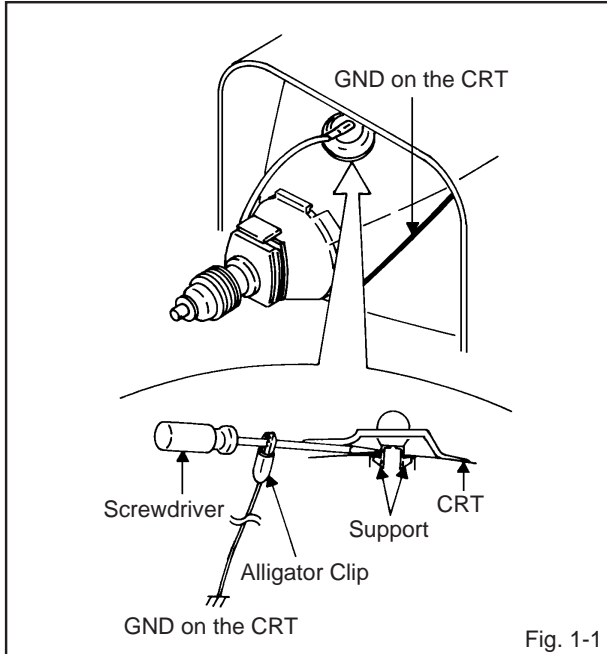

2. Flip up the sides of the Rubber Cap in the direction of the arrow and remove one side of the support. **(Refer to Fig. 1-2.)**

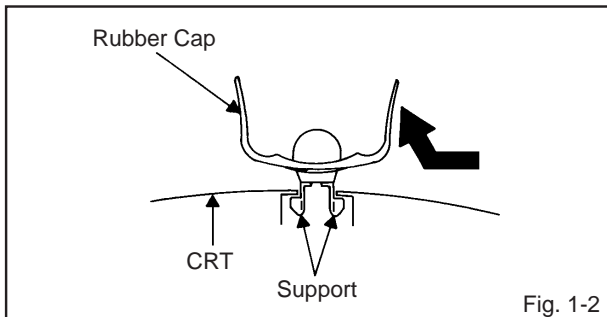

3. After one side is removed, pull in the opposite direction to remove the other.

NOTE

Take care not to damage the Rubber Cap.

INSTALLATION

1. Clean the spot where the cap was located with a small amount of alcohol. **(Refer to Fig. 1-3.)**

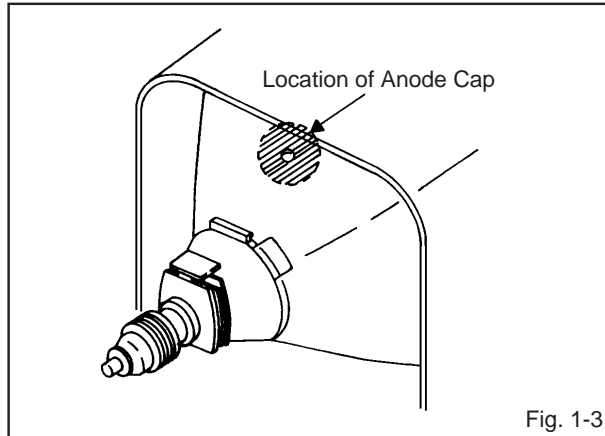

NOTE

Confirm that there is no dirt, dust, etc. at the spot where the cap was located.

2. Arrange the wire of the Anode Cap and make sure the wire is not twisted.
3. Turn over the Rubber Cap. **(Refer to Fig. 1-4.)**

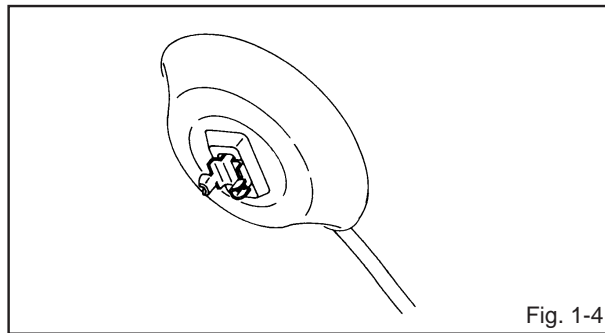

4. Insert one end of the Anode Support into the anode button, then the other as shown in **Fig. 1-5.**

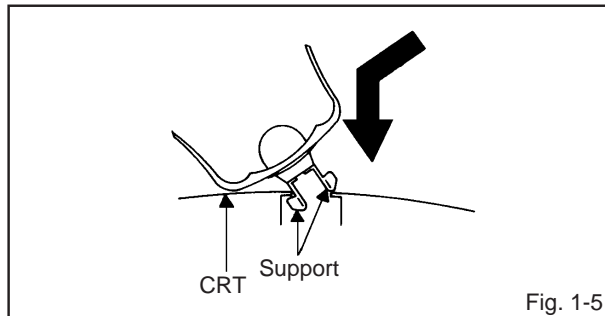

5. Confirm that the Support is securely connected.
 6. Put on the Rubber Cap without moving any parts.
- No.51911

DISASSEMBLY INSTRUCTIONS

2. REMOVAL AND INSTALLATION OF FLAT PACKAGE IC

REMOVAL

1. Put the Masking Tape (cotton tape) around the Flat Package IC to protect other parts from any damage. (Refer to Fig. 2-1.)

NOTE

Masking is carried out on all the parts located within 10 mm distance from IC leads.

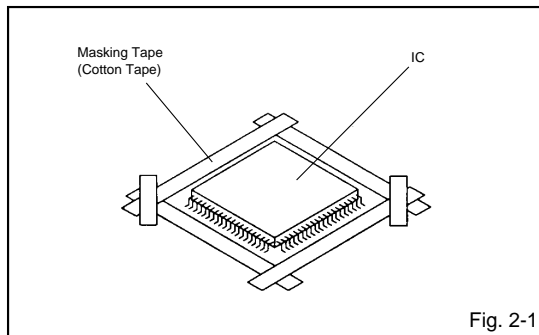

Fig. 2-1

2. Heat the IC leads using a blower type IC desoldering machine. (Refer to Fig. 2-2.)

NOTE

Do not add the rotating and the back and forth directions force on the IC, until IC can move back and forth easily after desoldering the IC leads completely.

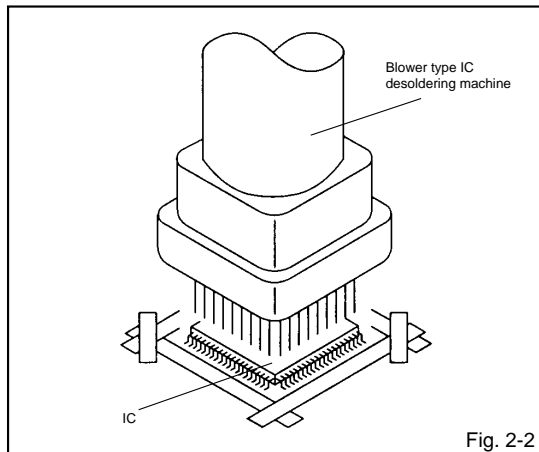

Fig. 2-2

3. When IC starts moving back and forth easily after desoldering completely, pickup the corner of the IC using a tweezers and remove the IC by moving with the IC desoldering machine. (Refer to Fig. 2-3.)

NOTE

Some ICs on the PCB are affixed with glue, so be careful not to break or damage the foil of each IC leads or solder lands under the IC when removing it.

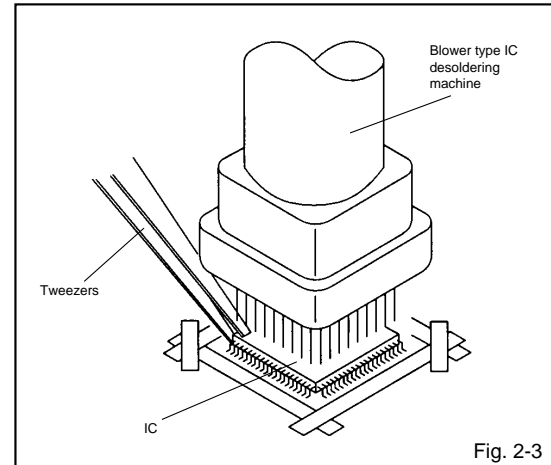

Fig. 2-3

4. Peel off the Masking Tape.
5. Absorb the solder left on the pattern using the Braided Shield Wire. (Refer to Fig. 2-4.)

NOTE

Do not move the Braided Shield Wire in the vertical direction towards the IC pattern.

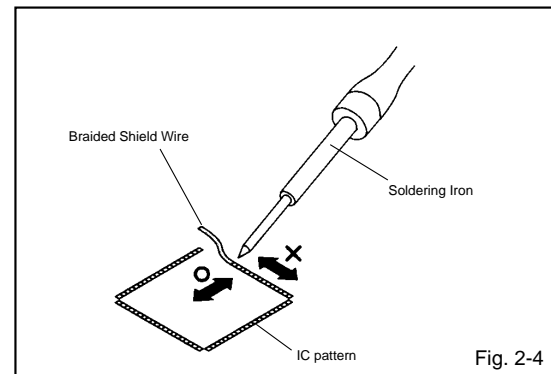
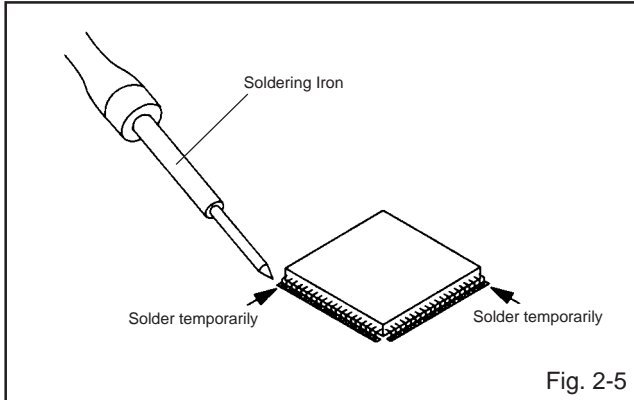

Fig. 2-4

DISASSEMBLY INSTRUCTIONS

INSTALLATION

1. Take care of the polarity of new IC and then install the new IC fitting on the printed circuit pattern. Then solder each lead on the diagonal positions of IC temporarily. **(Refer to Fig. 2-5.)**



2. Supply the solder from the upper position of IC leads sliding to the lower position of the IC leads. **(Refer to Fig. 2-6.)**

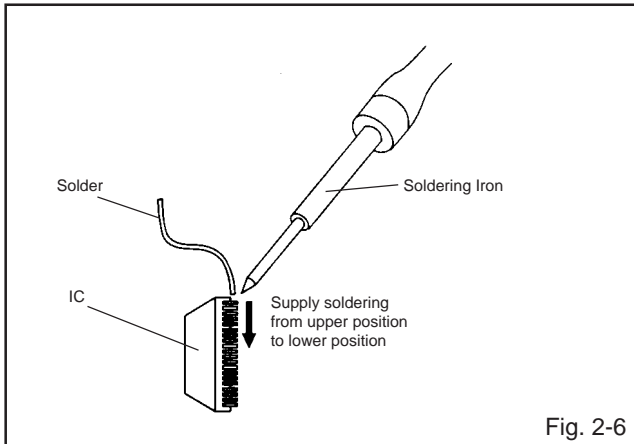

3. Absorb the solder left on the lead using the Braided Shield Wire. **(Refer to Fig. 2-7.)**

NOTE

Do not absorb the solder to excess.

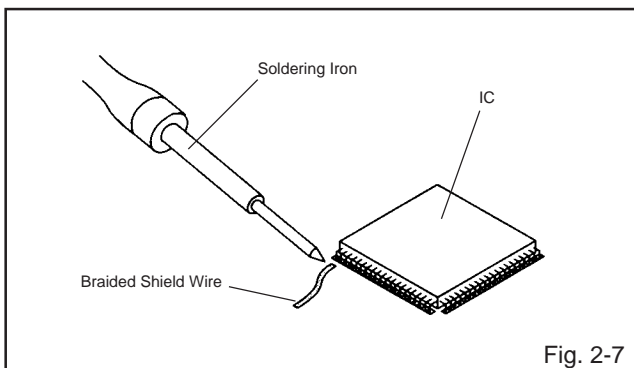

4. When bridge-soldering between terminals and/or the soldering amount are not enough, resolder using a Thin-tip Soldering Iron. **(Refer to Fig. 2-8.)**

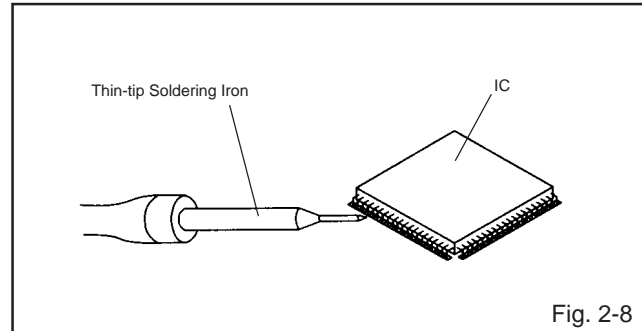

5. Finally, confirm the soldering status on four sides of the IC using a magnifying glass. Confirm that no abnormality is found on the soldering position and installation position of the parts around the IC. If some abnormality is found, correct by resoldering.

NOTE

When the IC leads are bent during soldering and/or repairing, do not repair the bending of leads. If the bending of leads are repaired, the pattern may be damaged. So, be always sure to replace the IC in this case.

SERVICE MODE LIST

This unit provided with the following SERVICE MODES so you can repair, examine and adjust easily. To enter the Service Mode, press both set key and remote control key for more than 1 second.

Set Key	Remocon Key	Operations
VOL. (-) MIN	0	Releasing of V-CHIP PASSWORD.
VOL. (-) MIN	1	Initialization of the factory. NOTE: Do not use this for the normal servicing.
VOL. (-) MIN	6	POWER ON total hours is displayed on the screen. Refer to the "CONFIRMATION OF USING HOURS". Can be checked of the INITIAL DATA of MEMORY IC. Refer to the "NOTE FOR THE REPLACING OF MEMORY IC".
VOL. (-) MIN	8	Writing of EEPROM initial data. NOTE: Do not use this for the normal servicing.
VOL. (-) MIN	9	Display of the Adjustment MENU on the screen. Refer to the "ELECTRICAL ADJUSTMENT" (On-Screen Display Adjustment).

CONFIRMATION OF USING HOURS

POWER ON total hours can be checked on the screen. Total hours are displayed in 16 system of notation.

1. Set the VOLUME to minimum.
2. Press both VOL. DOWN button on the set and Channel button **(6)** on the remote control for more than 1 second.
3. After the confirmation of using hours, turn off the power.

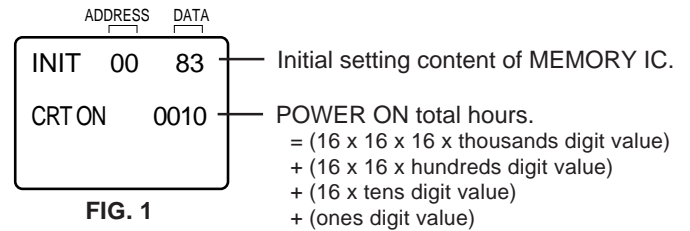

NOTE FOR THE REPLACING OF MEMORY IC

If a service repair is undertaken where it has been required to change the MEMORY IC, the following steps should be taken to ensure correct data settings while making reference to TABLE 1.

INI	+0	+1	+2	+3	+4	+5	+6	+7	+8	+9	+A	+B	+C	+D	+E	+F
00	E1	C3	02	00	31	B3	AF	37	BF	60	FF	84	00	00	00	39
10	0F	---	---	---	---	---	---	---	---	---	---	---	---	---	---	---

Table 1

1. Enter DATA SET mode by setting VOLUME to minimum.
2. Press both VOL. DOWN button on the set and Channel button **(6)** on the remote control for more than 1 second. ADDRESS and DATA should appear as FIG 1.
3. ADDRESS is now selected and should "blink". Using the VOL. UP/DOWN button on the remote, step through the ADDRESS until required ADDRESS to be changed is reached.
4. Press ENTER to select DATA. When DATA is selected, it will "blink".
5. Again, step through the DATA using VOL. UP/DOWN button until required DATA value has been selected.
6. Pressing ENTER will take you back to ADDRESS for further selection if necessary.
7. Repeat steps 3 to 6 until all data has been checked.
8. When satisfied correct DATA has been entered, turn POWER off (return to STANDBY MODE) to finish DATA input. The unit will now have the correct DATA for the new MEMORY IC.

SERVICE ADJUSTMENT

ELECTRICAL ADJUSTMENTS

1. BEFORE MAKING ELECTRICAL ADJUSTMENTS

Read and perform these adjustments when repairing the circuits or replacing electrical parts or PCB assemblies.

CAUTION

- Use an isolation transformer when performing any service on this chassis.
- Before removing the anode cap, discharge electricity because it contains high voltage.
- When removing a PCB or related component, after unfastening or changing a wire, be sure to put the wire back in its original position.
Inferior silicon grease can damage IC's and transistors.
- When replacing IC's and transistors, use only specified silicon grease.
Remove all old silicon before applying new silicon.

Prepare the following measurement tools for electrical adjustments.

1. Oscilloscope
2. Digital Voltmeter

On-Screen Display Adjustment

1. In the condition of NO indication on the screen.
Press the VOL. DOWN button on the set and the Channel button (9) on the remote control for more than 1 second to appear the adjustment mode on the screen as shown in Fig. 1-1.

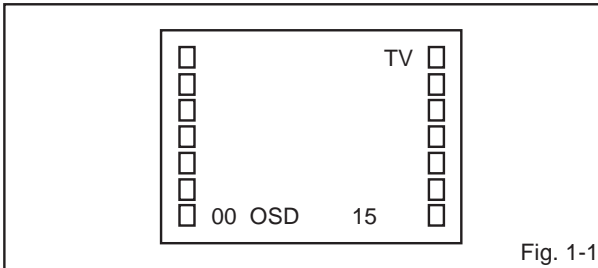

Fig. 1-1

2. Use the Channel UP/DOWN button or Channel button (0-9) on the remote control to select the options shown in Fig. 1-2.
3. Press the MENU button on the remote control to end the adjustments.

NO.	FUNCTION	NO.	FUNCTION
00	OSD H	17	SUBCONT
01	CUT OFF	18	UNI COL
02	RF. AGC	19	---
03	---	20	TINT
04	H. POSI	21	SHARP
05	V. POSI	22	RGB CONT
06	H. SIZE	23	PARABOLA
07	V. SIZE	24	TRAPEZIU
08	V. CENT	25	COR TOP
09	V. LIN	26	COR BTM
10	VS. CORR	27	V EHT
11	G. DRV	28	H EHT
12	B. DRV	29	FM. LVL
13	R. BIAS	30	LEVEL
14	G. BIAS	31	SEP1
15	B. BIAS	32	SEP2
16	BRI	33	T. STE

Fig. 1-2

2. BASIC ADJUSTMENTS

2-1: CONSTANT VOLTAGE

1. Set condition is AV MODE without signal.
2. Connect the digital voltmeter to **TP002**.
3. Adjust the **VR502** until the digital voltmeter is $116 \pm 1V$.

2-2: RF AGC

1. Receive a 63dB monoscope pattern.
2. Connect the digital voltmeter between the **TP001** and the **GND**.
3. Activate the adjustment mode display of Fig. 1-1 and press the channel button (02) on the remote control to select "RF. AGC".
4. Press the VOL. UP/DOWN button on the remote control until the digital voltmeter is $2.5 \pm 0.05V$.

2-3: CUT OFF

1. Adjust the unit to the following settings.
G. DRIVE=64, B. DRIVE=64, R. BIAS=32, G. BIAS=32, B. BIAS=32, BRIGHTNESS=70, UNI COLOR=64
2. Place the set with Aging Test for more than 15 minutes.
3. Activate the adjustment mode display of Fig. 1-1 and press the channel button (01) on the remote control to select "CUT OFF".
4. Adjust the **Screen Volume** until a dim raster is obtained.

2-4: WHITE BALANCE

NOTE: Adjust after performing CUT OFF adjustment.

1. Place the set with Aging Test for more than 10 minutes.
2. Receive the white 100% signal from the Pattern Generator.
3. Using the adjustment control, set the brightness and contrast to normal position.
4. Activate the adjustment mode display of Fig. 1-1 and press the channel button (13) on the remote control to select "R. BIAS".
5. Using the VOL. UP/DOWN button on the remote control, adjust the R. BIAS.
6. Press the CH. UP/DOWN button on the remote control to select the "G. DRV", "B. DRV", "G. BIAS" or "B. BIAS".
7. Using the VOL. UP/DOWN button on the remote control, adjust the G. DRV, B. DRV, G. BIAS or B. BIAS.
8. Perform the above adjustments 6 and 7 until the white color is looked like a white.

2-5: FOCUS

1. Receive a 70dB monoscope pattern.
2. Turn the Focus Volume fully counterclockwise once.
3. Adjust the **Focus Volume** until picture is distinct.

2-6: HORIZONTAL POSITION

1. Receive the center cross signal from the Pattern Generator.
2. Using the remote control, set the brightness and contrast to normal position.
3. Activate the adjustment mode display of Fig. 1-1 and press the channel button (04) on the remote control to select "H. POSI".
4. Press the VOL. UP/DOWN button on the remote control until the right and left screen size of the vertical line becomes the same.

ELECTRICAL ADJUSTMENTS

2-7: HORIZONTAL SIZE

NOTE: Adjust after performing adjustments in section 2-6.

1. Receive the monoscope pattern.
2. Using the remote control, set the brightness and contrast to normal position.
3. Activate the adjustment mode display of **Fig. 1-1** and press the channel button **(06)** on the remote control to select "H. SIZE".
4. Press the VOL. UP/DOWN button on the remote control until the SHIFT quantity of the OVER SCAN on right and left becomes 10 ± 2%.

2-8: VERTICAL POSITION

NOTE: Adjust after performing adjustments in section 2-7.

1. Receive the center cross signal from the Pattern Generator.
2. Activate the adjustment mode display of **Fig. 1-1** and press the channel button **(05)** on the remote control to select "V. POSI".
3. Press the VOL. UP/DOWN button on the remote control until the horizontal line becomes fit to the notch of the shadow mask.

2-9: VERTICAL SIZE

NOTE: Adjust after performing adjustments in section 2-8.

1. Receive the crosshatch signal from the Pattern Generator.
2. Activate the adjustment mode display of **Fig. 1-1** and press the channel button **(07)** on the remote control to select "V. SIZE".
3. Press the VOL. UP/DOWN button on the remote control until the rectangle on the center of the screen becomes square.
4. Receive a broadcast and check if the picture is normal.

2-10: PARABOLA

1. Receive the crosshatch signal from the Pattern Generator.
2. Using the remote control, set the brightness and contrast to normal position.
3. Activate the adjustment mode display of **Fig. 1-1** and press the channel button **(23)** on the remote control to select "PARABOLA".
4. Press the VOL. UP/DOWN button on the remote control until the right and left vertical lines are straight.

2-11: TRAPEZIUM

1. Receive the crosshatch signal from the Pattern Generator.
2. Using the remote control, set the brightness and contrast to normal position.
3. Activate the adjustment mode display of **Fig. 1-1** and press the channel button **(24)** on the remote control to select "TRAPEZIU".
4. Press the VOL. UP/DOWN button on the remote control until the both vertical lines of the screen become parallel.

2-12: CORNER CORR TOP

1. Receive the crosshatch signal from the Pattern Generator.
2. Using the remote control, set the brightness and contrast to normal position.
3. Activate the adjustment mode display of **Fig. 1-1** and press the channel button **(25)** on the remote control to select "COR TOP".
4. Press the VOL. UP/DOWN button on the remote control until the upper section of the both ends vertical lines are straight.

2-13: CORNER CORR BOTTOM

1. Receive the crosshatch signal from the Pattern Generator.
2. Using the remote control, set the brightness and contrast to normal position.
3. Activate the adjustment mode display of **Fig. 1-1** and press the channel button **(26)** on the remote control to select "COR BTM".
4. Press the VOL. UP/DOWN button on the remote control until the bottom section of the both ends vertical lines are straight.

2-14: OSD HORIZONTAL

1. Activate the adjustment mode display of **Fig. 1-1**.
2. Press the VOL. UP/DOWN button on the remote control until the difference of A and B becomes minimum.
(Refer to Fig. 2-1)

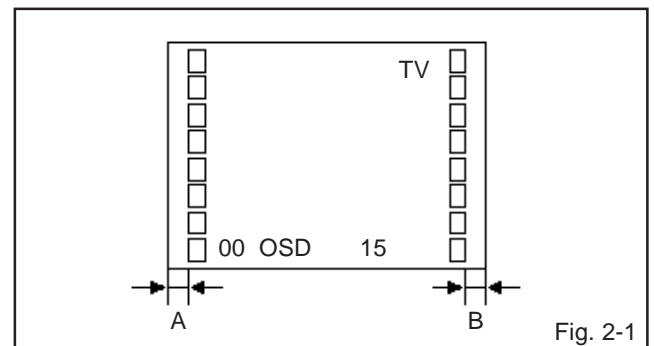

2-15: LEVEL

1. Receive a 70dB monoscope pattern.
2. Connect the AC voltmeter to **TP901**.
3. Activate the adjustment mode display of **Fig. 1-1** and press the channel button **(30)** on the remote control to select "LEVEL".
4. Press the VOL. UP/DOWN button on the remote control until the AC voltmeter is $75 \pm 2\text{mV}$.

ELECTRICAL ADJUSTMENTS

2-16: SEPARATION 1, 2

1. Receive the stereo signal (L=2KHz, R=400Hz).
2. Connect the AC voltmeter to **AUDIO OUT JACK** through stereo filter (L=400Hz, R=2KHz).
3. Activate the adjustment mode display of **Fig. 1-1** and press the channel button **(31)** on the remote control to select "SEP1".
4. Press the VOL. UP/DOWN button on the remote control until the output of L-CH and R-CH become minimum.
5. Press the CH UP button once the set to "SEP2" mode.
6. Press the VOL. UP/DOWN button on the remote control until the output of L-CH and R-CH become minimum.
7. Press the CH DOWN button once the set to "SEP1" mode.
8. Repeat step 4 to step 7 several times.
The output difference of the between with Filter and without Filter should be more than 25db for both L and R.

2-17: BRIGHTNESS

1. Activate the adjustment mode display of **Fig. 1-1** and press the channel button **(16)** on the remote control to select "BRI".
2. Press the VOL. UP/DOWN button on the remote control until the brightness step No. becomes "47"
3. Press the INPUT button on the remote control to set to the AV mode.
4. Activate the adjustment mode display of **Fig. 1-1** and press the channel button **(16)** on the remote control to select "BRI".
5. Press the VOL. UP/DOWN button on the remote control until the brightness step No. becomes "46"
6. Press the INPUT button on the remote control to set to the CS mode.
7. Activate the adjustment mode display of **Fig. 1-1** and press the channel button **(16)** on the remote control to select "BRI".
8. Press the VOL. UP/DOWN button on the remote control until the brightness step No. becomes "48"

2-18: UNI-COLOR

NOTE: Adjust after performing SUB TINT/SUB COLOR adjustment.

1. Activate the adjustment mode display of **Fig. 1-1** and press the channel button **(18)** on the remote control to select "UNI COL".
2. Press the VOL. UP/DOWN button on the remote control until the contrast step No. becomes "9"
3. Press the INPUT button on the remote control to set to the AV mode.
4. Activate the adjustment mode display of **Fig. 1-1** and press the channel button **(18)** on the remote control to select "UNI COL".
5. Press the VOL. UP/DOWN button on the remote control until the contrast step No. becomes "6"
6. Press the INPUT button on the remote control to set to the CS mode. Then perform the above adjustments 4~5.

2-19: SUB TINT/SUB COLOR

1. Receive the color bar pattern. (RF Input)
2. Connect the oscilloscope to **TP806**.
3. Activate the adjustment mode display of **Fig. 1-1** and press the channel button **(20)** on the remote control to select "TINT".
4. Press the VOL. UP/DOWN button on the remote control until the section "A" becomes a straight line **(Refer Fig. 2-2)**.
5. Connect the oscilloscope to **TP804**.
6. Press the CH DOWN button 3 times to set to "SUBCONT" mode.
7. Press the VOL. UP/DOWN button on the remote control until the red color level is adjusted to $110 \pm 0.5\%$ of the white level. **(Refer to Fig. 2-3)**
8. Receive the color bar pattern. (Audio Video Input)
9. Press the INPUT button on the remote control to set to the AV mode. Then perform the above adjustments 2~7.
10. Press the INPUT button on the remote control to set to the CS mode.
11. Activate the adjustment mode display of **Fig. 1-1** and press the channel button **(20)** on the remote control to select "TINT".
12. Press the VOL. UP/DOWN button on the remote control to increase the step numbers by 6 steps to the AV.
13. Press the CH DOWN button 3 times to set to "SUBCONT" mode.
14. Press the VOL. UP/DOWN button on the remote control to set the same step number as the AV.

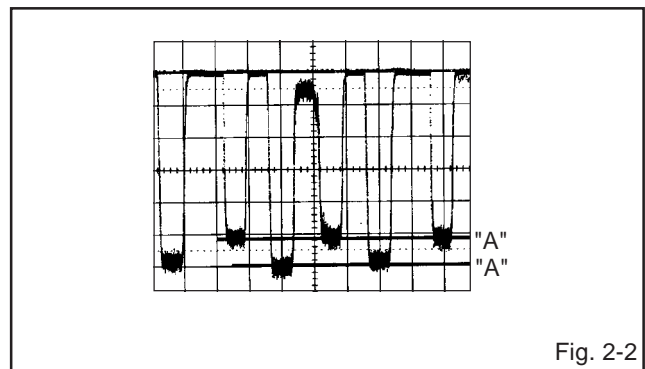

Fig. 2-2

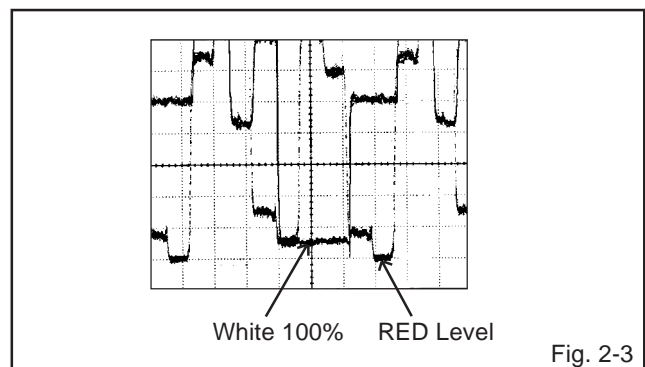

Fig. 2-3

ELECTRICAL ADJUSTMENTS

3. PURITY AND CONVERGENCE ADJUSTMENTS

NOTE

1. Turn the unit on and let it warm up for at least 30 minutes before performing the following adjustments.
2. Place the CRT surface facing east or west to reduce the terrestrial magnetism.
3. Turn ON the unit and demagnetize with a Degauss Coil.

3-1: STATIC CONVERGENCE (ROUGH ADJUSTMENT)

1. Tighten the screw for the magnet. Refer to the adjusted CRT for the position. **(Refer to Fig. 3-1)**
If the deflection yoke and magnet are in one body, untighten the screw for the body.
2. Receive the green raster pattern from the color bar generator.
3. Slide the deflection yoke until it touches the funnel side of the CRT.
4. Adjust center of screen to green, with red and blue on the sides, using the pair of purity magnets.
5. Switch the color bar generator from the green raster pattern to the crosshatch pattern.
6. Combine red and blue of the 3 color crosshatch pattern on the center of the screen by adjusting the pair of 4 pole magnets.
7. Combine red/blue (magenta) and green by adjusting the pair of 6 pole magnets.
8. Adjust the crosshatch pattern to change to white by repeating steps 6 and 7.

3-2: PURITY

NOTE

Adjust after performing adjustments in section 3-1.

1. Receive the green raster pattern from color bar generator.
2. Adjust the pair of purity magnets to center the color on the screen.
Adjust the pair of purity magnets so the color at the ends are equally wide.
3. Move the deflection yoke backward (to neck side) slowly, and stop it at the position when the whole screen is green.
4. Confirm red and blue colors.
5. Adjust the slant of the deflection yoke while watching the screen, then tighten the fixing screw.

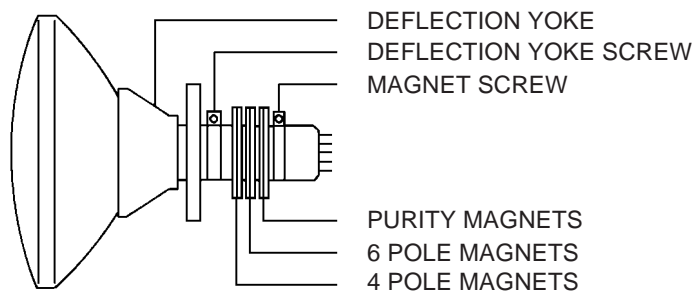

Fig. 3-1

3-3: STATIC CONVERGENCE

NOTE

Adjust after performing adjustments in section 3-2.

1. Receive the crosshatch pattern from the color bar generator.
2. Combine red and blue of the 3 color crosshatch pattern on the center of the screen by adjusting the pair of 4 pole magnets.
3. Combine red/blue (magenta) and green by adjusting the pair of 6 pole magnets.

3-4: DYNAMIC CONVERGENCE

NOTE

Adjust after performing adjustments in section 3-3.

1. Adjust the differences around the screen by moving the deflection yoke upward/downward and right/left. **(Refer to Fig. 3-2-a)**
2. Insert three wedges between the deflection yoke and CRT funnel to fix the deflection yoke. **(Refer to Fig. 3-2-b)**

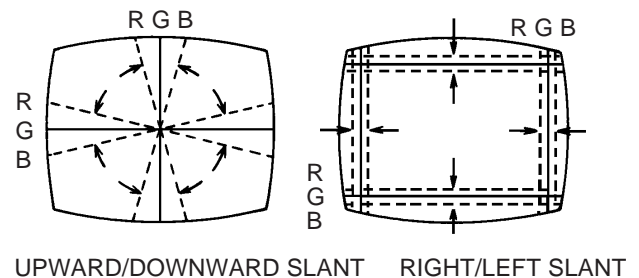

Fig. 3-2-a

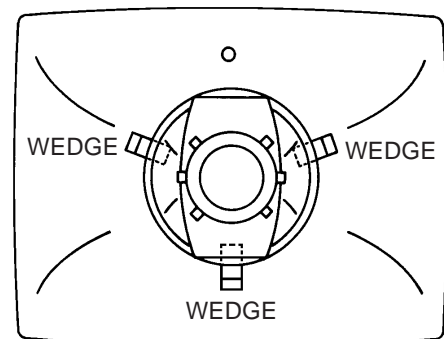
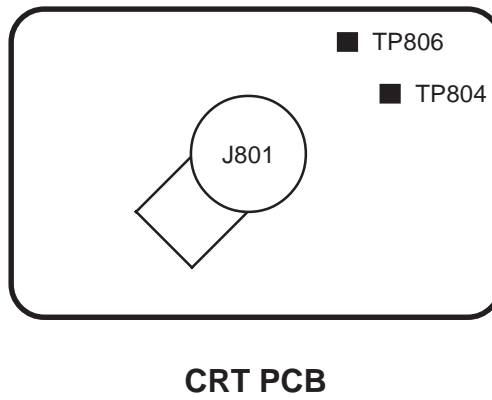
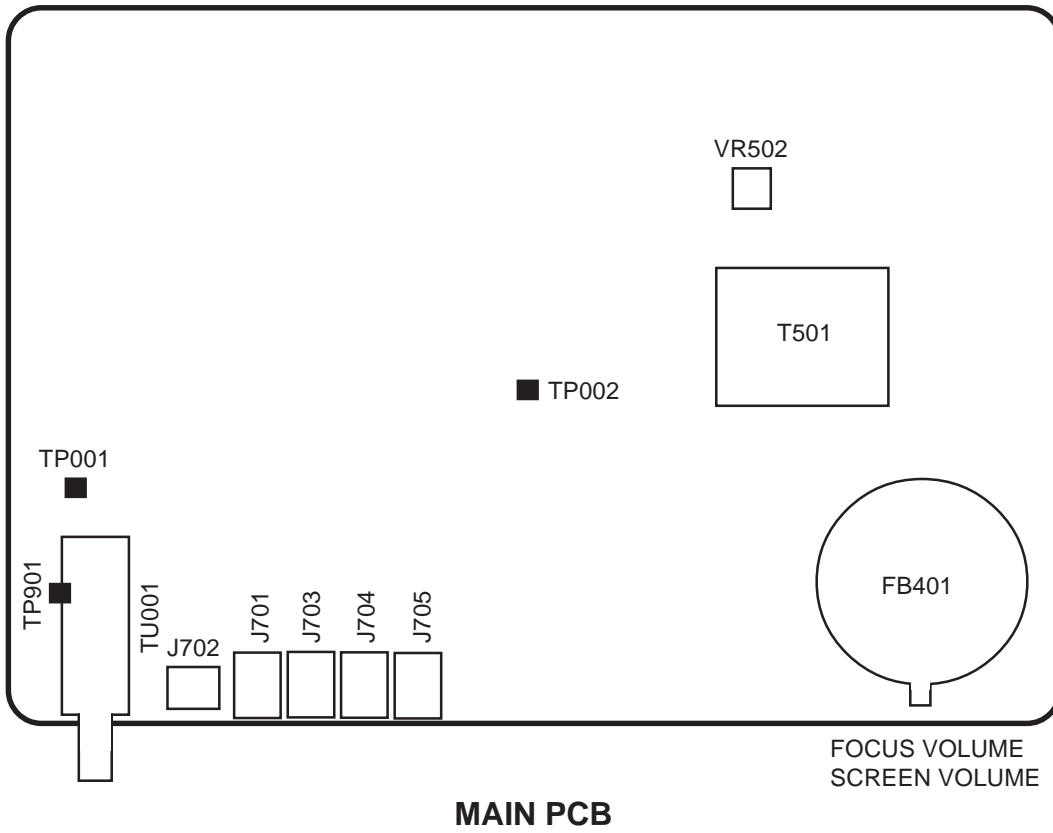

Fig. 3-2-b

MAJOR COMPONENTS LOCATION GUIDE



GUIDE FOR REPAIRING

IC DESCRIPTION

OEC7055B (IC101)

NO.	Symbol	I/O	Logic	Function	Option
1	H.SYNC	Input	0	Horizontal synchronization input	-
2	V.SYNC	Input	0	Vertical synchronization input	-
3	-	Input	-	Unused	-
4	REMOCON	Input	-	Remote control input	-
5	-	Input	-	Unused	-
6	SYNC	Input	-	Synchronization detector input	-
7	KEY1	Input	-	Voltage of the TV button input(power,vol down,ch down)	C-MOS
8	KEY2	Input	-	Voltage of the TV button input(vol up,ch up)	C-MOS
9	X-RAY	Input	-	X-RAY detector input	C-MOS
10	AFT	Input	-	Voltage of tuning input	C-MOS
11	-	Input	-	Unused	N-OD
12	-	Input	-	Unused	N-OD
13	-	Input	-	Unused	N-OD
14	-	Output	-	Unused	C-MOS
15	POWER FAIL	Input	0	Power failure detector input	-
16	-	Input	-	Unused	N-OD
17	-	Input	-	Unused	N-OD
18	AVCC	-	-	Positive power supply for analog block (5v nom,)	-
19	HLF	-	-	Filter for CCD	-
20	RVCO	-	-	Resistor for CCD	-
21	VHOLD	-	-	Capacity for CCD	-
22	CVIN	I	-	Video signal for CCD	-
23	CNVSS	-	-	Negative power supply for analog block (ground)	-
24	XIN	Input	-	Main Oscillation (8MHz)	-
25	XOUT	Output	-	Main Oscillation (8MHz)	-
26	VSS	-	-	Negative power supply for digital block (ground)	-
27	VCC	-	-	Positive power supply for digital block (5v nom,)	-
28	OSC1	-	Input	Oscillation for OSD	-
29	OSC2	-	Output	Oscillation for OSD	-
30	RESET	Input	0	Reset signal input	-
31	AV1	O	-	External SW outoutput1	C-MOS
32	AV2	O	-	External SW outoutput2	C-MOS
33	ON TIMER	O	1	On timer LED output	C-MOS
34	DEGAUSS H	O	1	Degauss output	C-MOS
35	SPOT OFF	O	0	Spot killer output	C-MOS
36	-	I	-	Unused	N-OD
37	SDA	I/O	1	Serial data input/output	N-OD
38	-	I	-	Unused	N-OD
39	SCL	O	1	Serial clock output	N-OD
40	HALF TONE	O	1	Half tone output	C-MOS
41	POWER	O	1	Power control output	C-MOS
42	COMP H	O	1	Component output	C-MOS
43	IIC OFF	I	0	Serial clock/data stop input	C-MOS
44	BBE H	O	1	BBE control output	C-MOS
45	TV MUTE	O	0	Volume muting output for loudspeaker	N-OD
46	EXT MUTE	O	1	Volume muting output for external	N-OD
47	-	O	-	Unused	N-OD
48	X RAY TEST	O	1	X-RAY test output	N-OD
49	BL	O	1	Fast blanking control signal	C-MOS
50	B	O	1	Blue output of OSD	C-MOS
51	G	O	1	Green output of OSD	C-MOS
52	R	O	1	Red output of OSD	C-MOS

TROUBLESHOOTING GUIDE

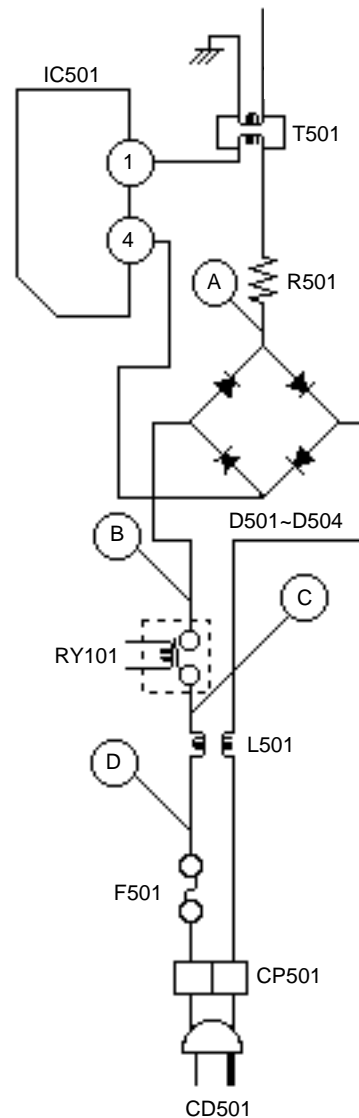
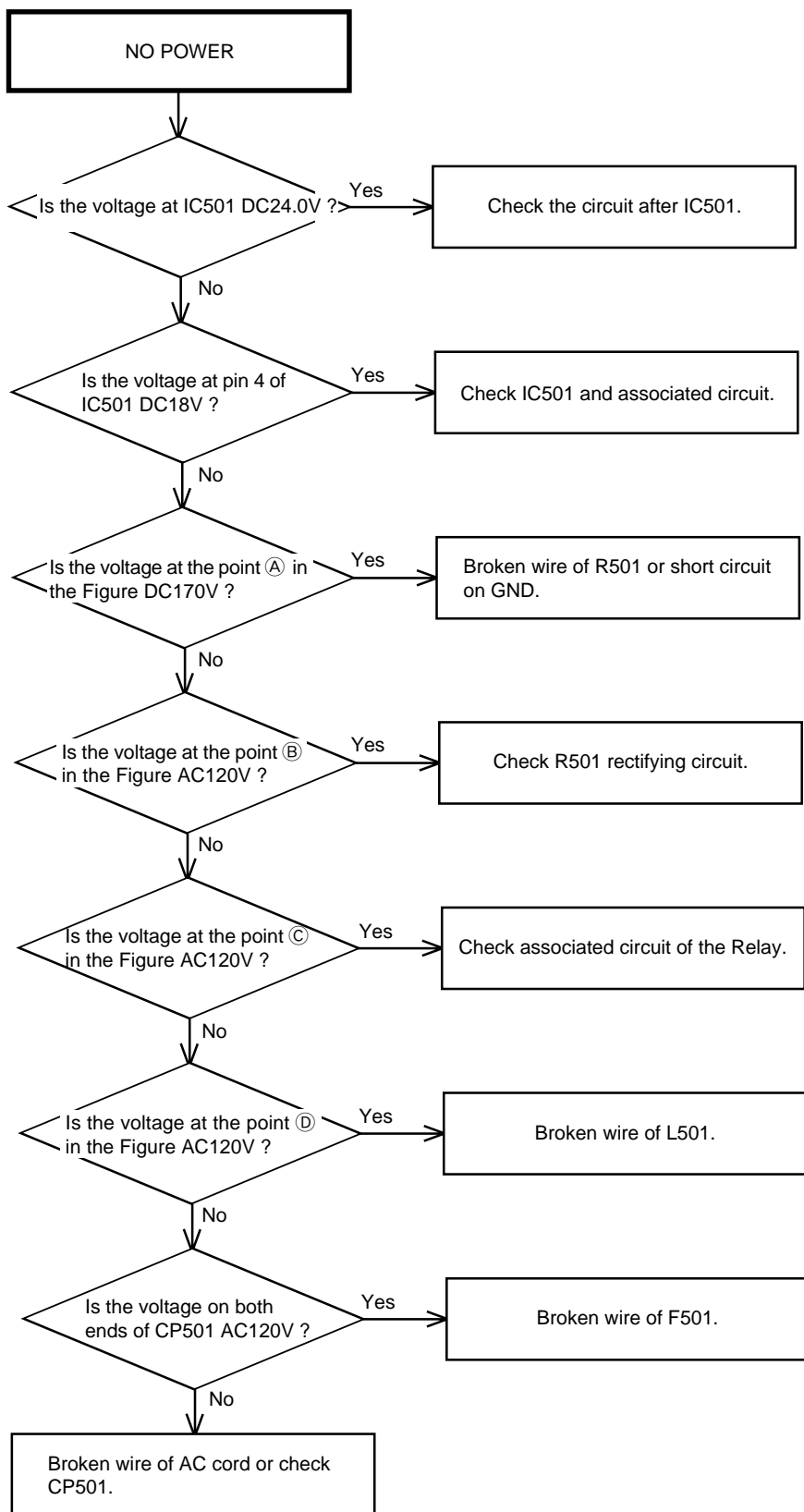

TROUBLESHOOTING GUIDE

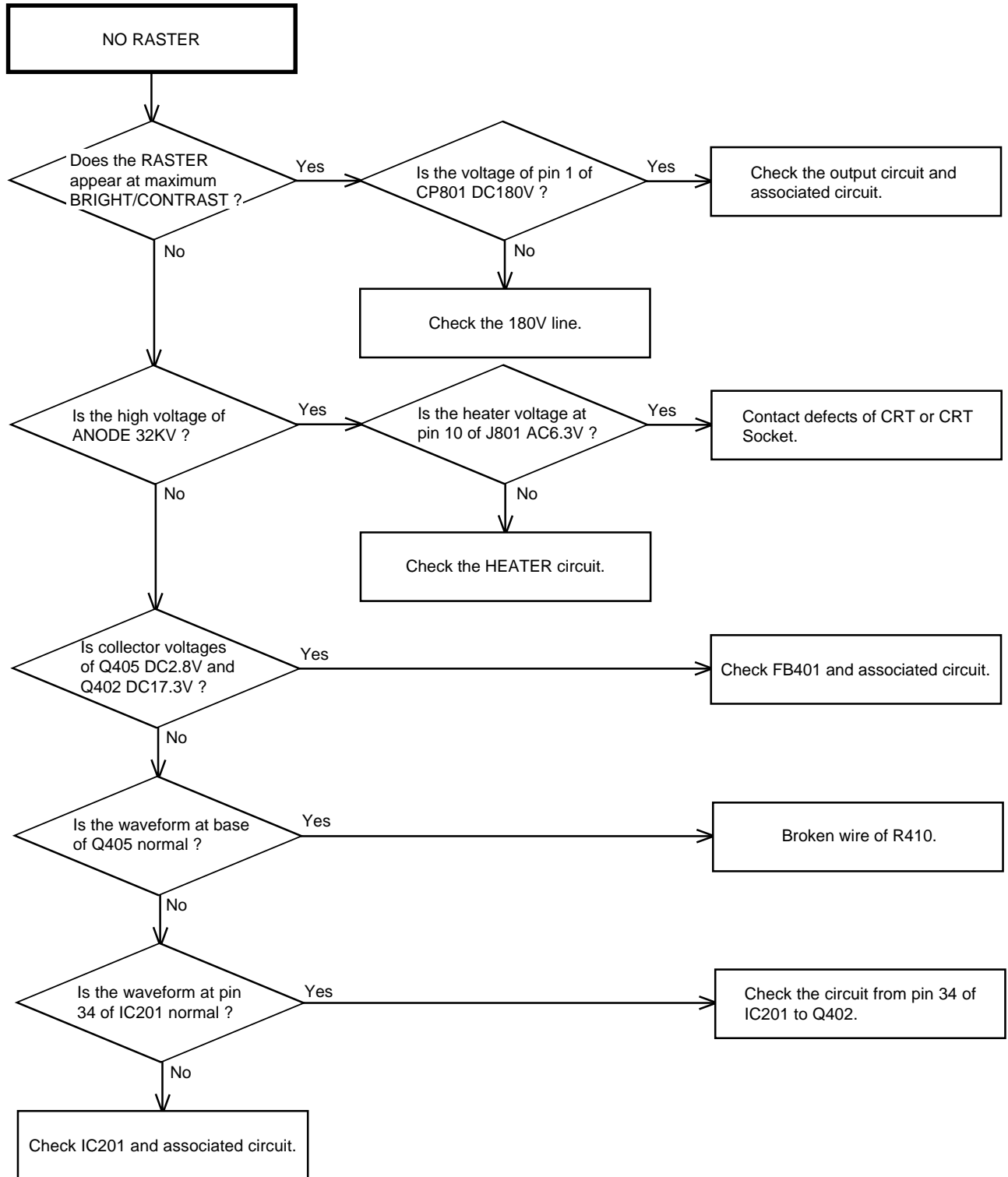

TROUBLESHOOTING GUIDE

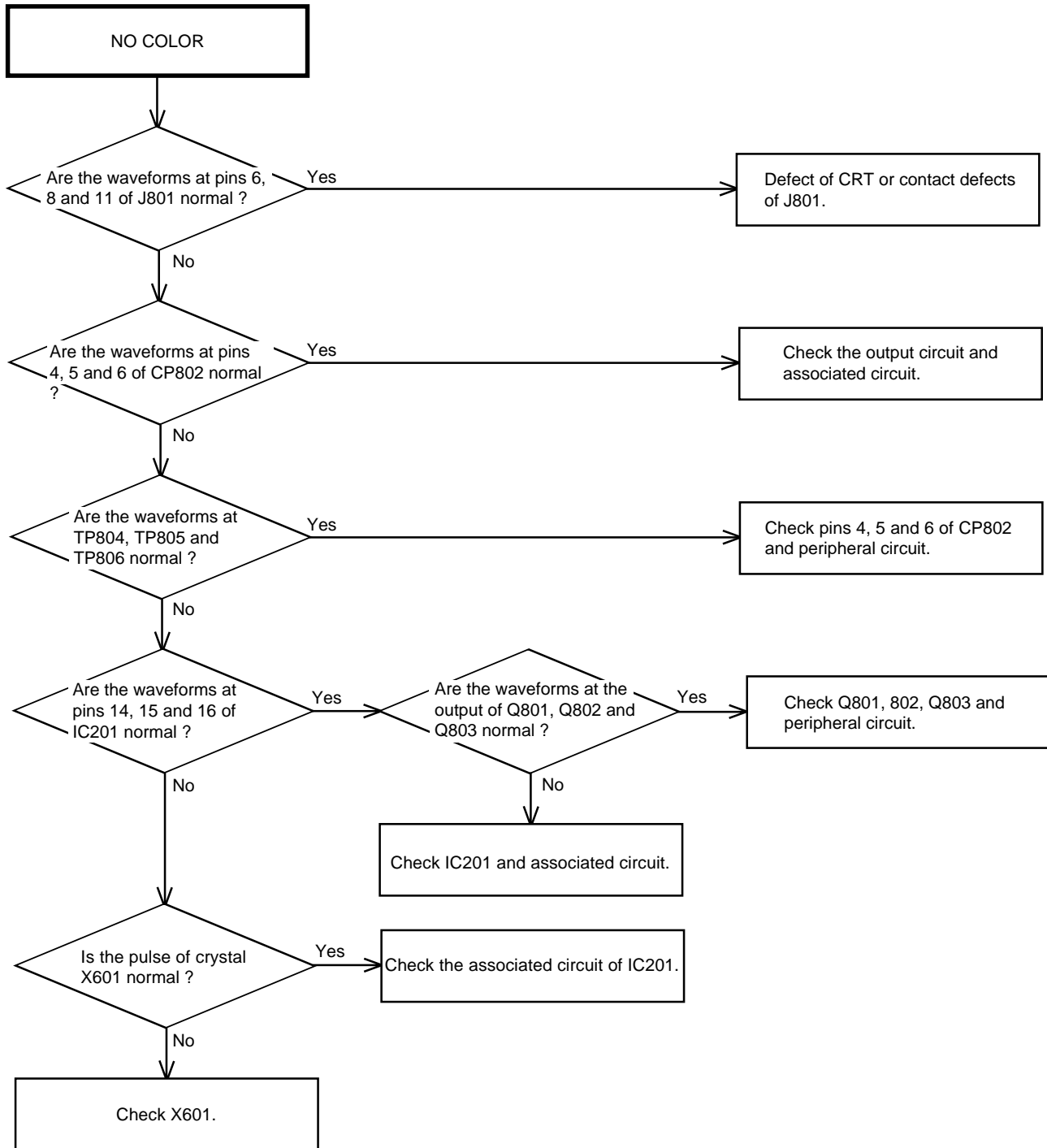

TROUBLESHOOTING GUIDE

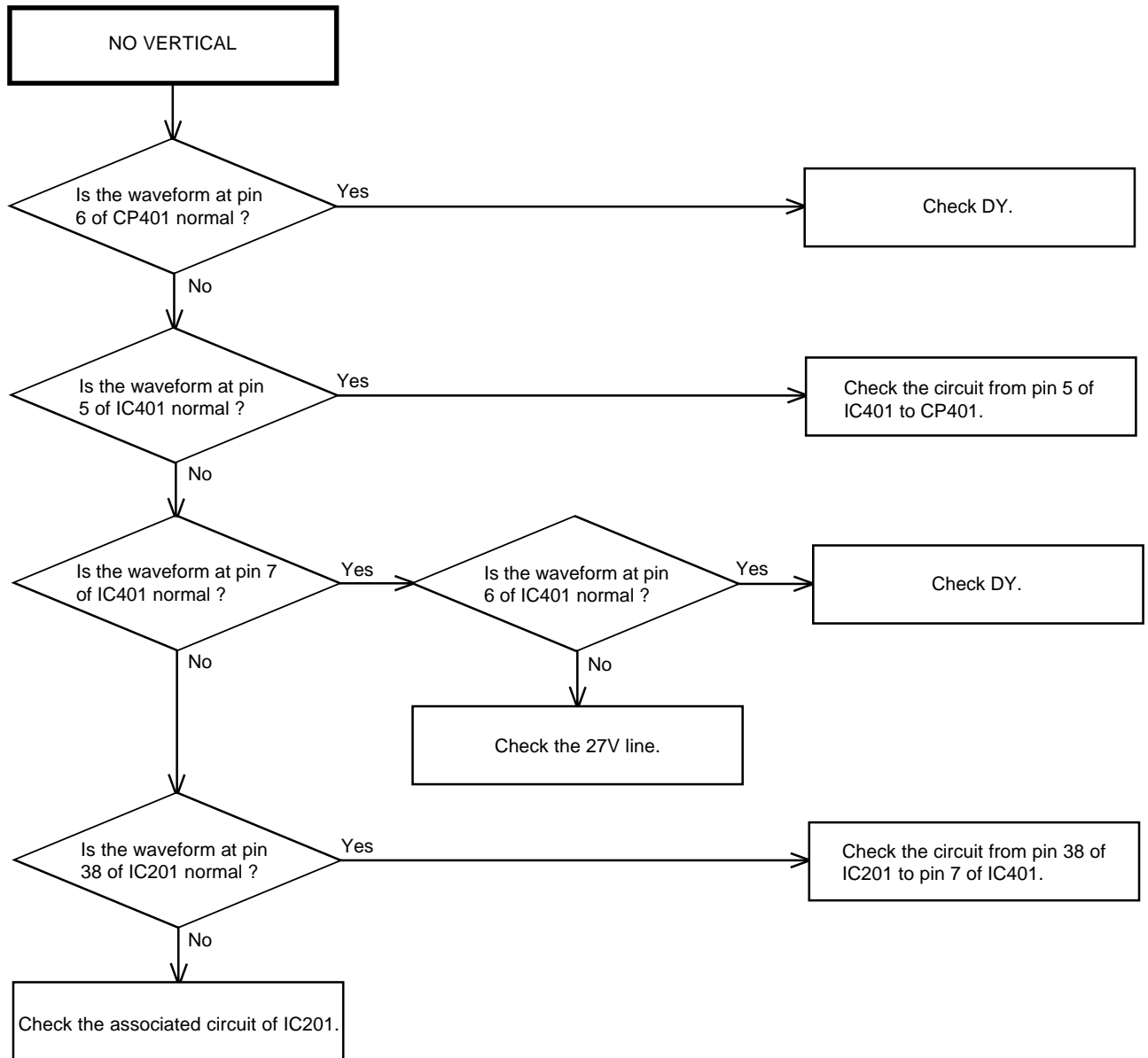

TROUBLESHOOTING GUIDE

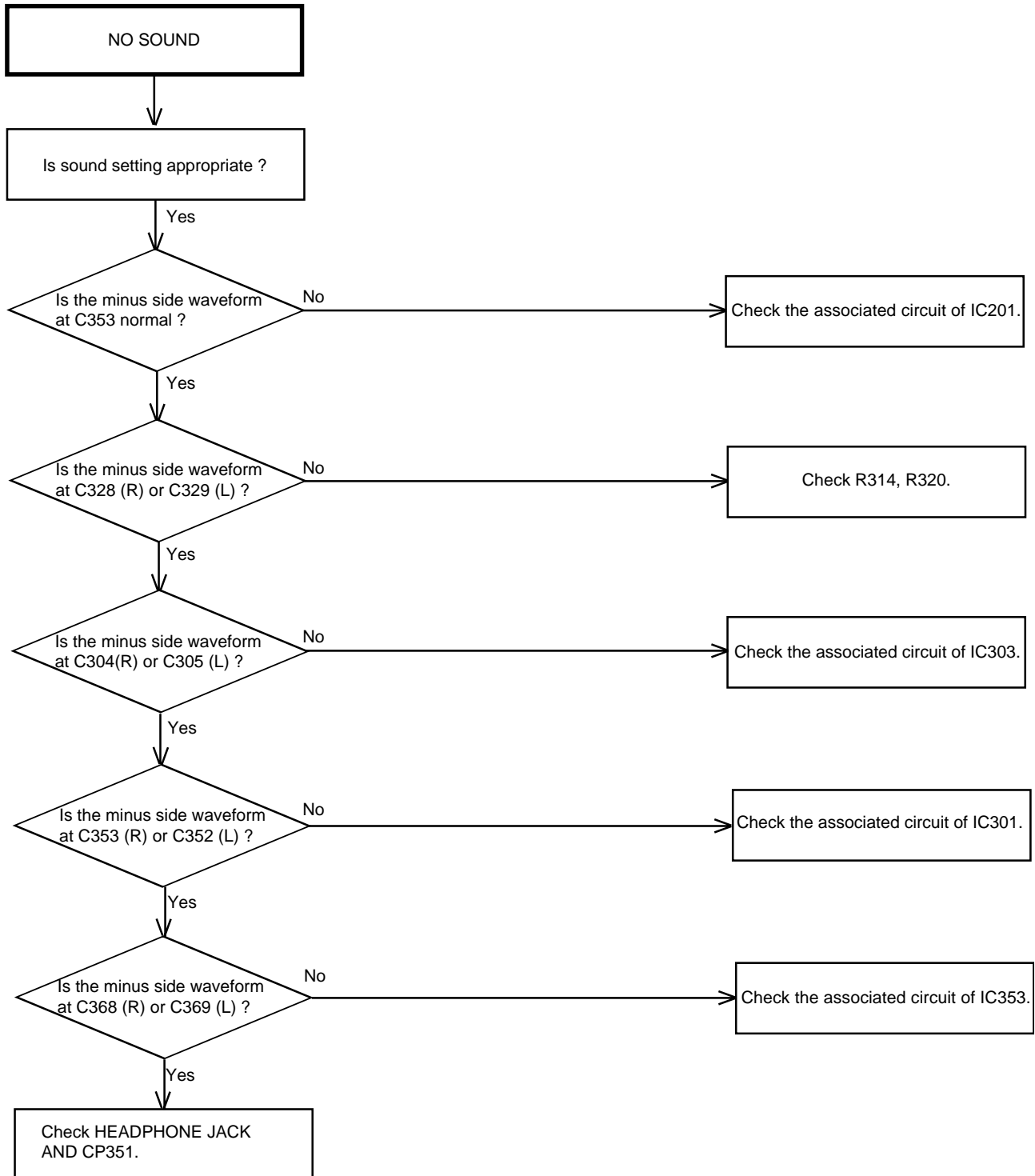

TROUBLESHOOTING GUIDE

